

TECHNICAL DETAILS		METRIC	INCH
OPERATING CONDITIONS			
MAXIMUM SPEED	1.0 m/sec	3.0 ft/sec	
TEMPERATURE RANGE	-45°C + 110°C	-50°F + 230°F	
MAXIMUM PRESSURE	400 bar	6000 p.s.i.	
MAXIMUM EXTRUSION GAP			
PRESSURE bar	160	250	400
MAXIMUM GAP mm	0.6	0.5	0.4
PRESSURE p.s.i.	2400	3750	6000
MAXIMUM GAP in	0.024	0.020	0.016
SURFACE ROUGHNESS			
DYNAMIC SEALING FACE $\varnothing D_1$	μmRa 0.1 ↔ 0.4	μmRt 4 max	μinCLA 4 ↔ 16 μinRMS 5 ↔ 18
STATIC SEALING FACE $\varnothing d_1$	1.6 max	10 max	63 max 70 max
STATIC HOUSING FACES L_1	3.2 max	16 max	125 max 140 max
CHAMFERS & RADII			
GROOVE SECTION $\leq S$ mm	4.0	5.0	7.5
MIN CHAMFER C mm	3.0	3.5	5.0
MAX FILLET RAD r_1 mm	0.2	0.4	0.8
GROOVE SECTION $\leq S$ in	0.125	0.187	0.250
MIN CHAMFER C in	0.093	0.093	0.125
MAX FILLET RAD r_1 in	0.008	0.008	0.016
TOLERANCES			
	$\varnothing D_1$	$\varnothing d_1$	L_1
mm	H9	js11	+0.25 -0
in	+0.004 -0	0 -0.002	+0.010 -0

Figures show the maximum permissible gap all on one side using the minimum clearance \varnothing and maximum bore \varnothing

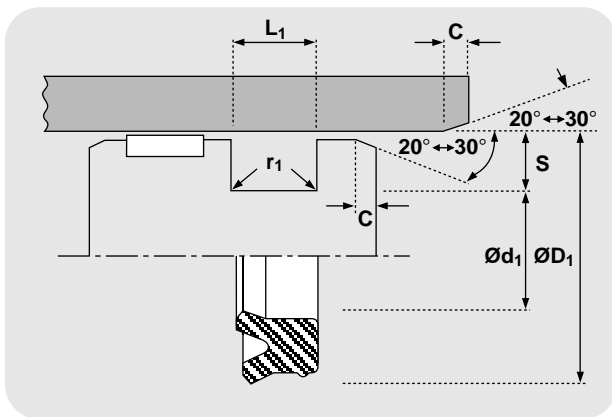

FEATURES

- FLEXIBLE FOR EASY INSTALLATION
- EXCELLENT WEAR RESISTANCE
- HIGH RESISTANCE TO EXTRUSION
- WIDE TEMPERATURE RANGE
- TWIN LIP DESIGN FOR:
 - IMPROVED SEALING
 - LOWER FRICTION
 - INCREASED SEAL STABILITY
 - PRIMARY LIP PROTECTION

DESIGN

The Hallite 659 is an asymmetric piston seal designed to offer effective bore sealing in a wide variety of applications.

The outer *dynamic* lip is shorter and more robust to provide improved sealing and compression set characteristics over conventional U rings. The seal also features a secondary lip that provides a pocket for lubrication as well as the benefits listed below.

For use in single acting applications only, the seal is manufactured in Hallite's high performance polyurethane Hythane 181. The Hallite 659 provides the following benefits:

Note: Variations of this seal are available in other sizes, please contact your local Hallite sales office for additional information and technical details.

Piston seals

659

metric

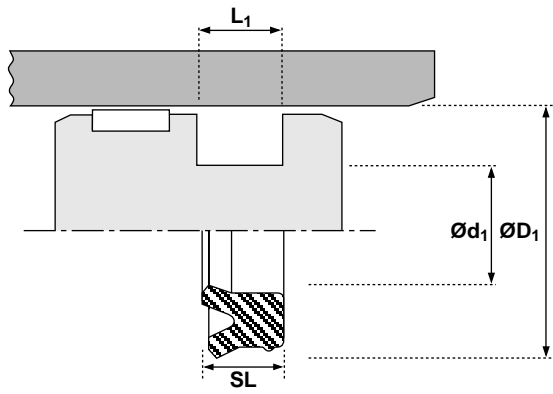

ØD ₁	TOL H9	Ød ₁	TOL js11	SL	L ₁ + 0.25 -0	PART No.
100.00	+0.09 +0.00	80.00	+0.11 -0.11	14.50	16.00	4580300

ØD ₁	TOL H9	Ød ₁	TOL js11	SL	L ₁ + 0.25 -0	PART No.
110.00	+0.09 +0.00	90.00	+0.11 -0.11	14.50	16.00	4580400

inch

ØD ₁	TOL	Ød ₁	TOL	SL	L ₁ + 0.010 -0	PART No.
1.250	+0.004 -0.000	1.000	+0.000 -0.002	0.171	0.187	4416600
1.500	+0.004 -0.000	1.250	+0.000 -0.002	0.187	0.207	4372400
1.750	+0.004 -0.000	1.250	+0.000 -0.002	0.375	0.413	4528600
2.000	+0.004 -0.000	1.630	+0.000 -0.002	0.250	0.281	4563300Δ
2.375	+0.004 -0.000	1.750	+0.000 -0.002	0.437	0.481	4528500
2.500	+0.004 -0.000	2.130	+0.000 -0.002	0.250	0.281	4563400Δ
3.000	+0.004 -0.000	2.250	+0.000 -0.002	0.500	0.550	4528400
3.000	+0.004 -0.000	2.630	+0.000 -0.002	0.250	0.281	4563500Δ

ØD ₁	TOL	Ød ₁	TOL	SL	L ₁ + 0.010 -0	PART No.
3.500	+0.004 -0.000	3.130	+0.000 -0.002	0.250	0.281	4563600Δ
3.625	+0.004 -0.000	2.875	+0.000 -0.002	0.562	0.619	4528300
4.000	+0.004 -0.000	3.630	+0.000 -0.002	0.250	0.281	4563700Δ
4.250	+0.004 -0.000	3.500	+0.000 -0.002	0.562	0.619	4528200
5.000	+0.004 -0.000	4.000	+0.000 -0.002	0.731	0.804	4528100
6.000	+0.004 -0.000	5.000	+0.000 -0.002	0.731	0.804	4530200
7.000	+0.004 -0.000	6.000	+0.000 -0.002	0.731	0.804	4529700

Δ Denotes parts designed to fit inch standard O ring grooves.