

Design

A robust seal assembly designed specifically for one piece pistons, the Hallite 64 double acting seal uses a rubber sealing element which has proved itself in service to be extremely wear resistant and capable of working most effectively in a wide variety of medium to heavy duty applications.

The assembly comprises a rubber seal, two split support rings and two split bearings, one of each located either side of the seal. The nitrile rubber seal is designed to have its section compressed by the housing, to ensure a low pressure seal, and when pressurised be protected from extrusion damage by the extending lips of the support ring. The support ring is manufactured from a tough but flexible polymer and scarf cut for assembly.

L section bearings provide the support and guidance for the piston and the other parts of the seal.

For seals up to 90mm diameter Ød_3 is not required. Above 90mm diameter the seals benefit from the additional support of the L-section bearings.

All seals are also suitable for two piece housings.

Note: Other sizes of this design of seal are shown under Hallite 50, 53 and 68. Also see Hallite 753 for interchangeable sizes.

Features

- Compact seal design
- Easy assembly
- Positive no drift seal

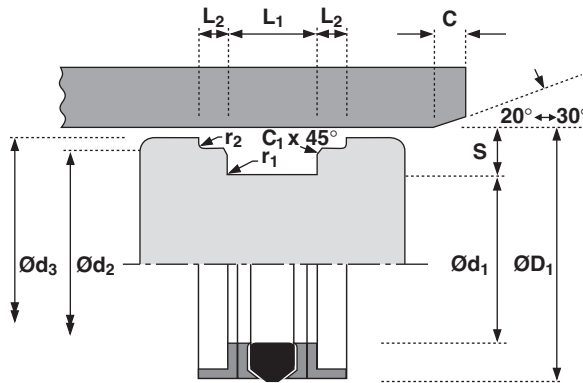

Technical details

Operating conditions

Maximum Speed	0.5 m/sec
Temperature Range	-30°C +100°C
Maximum Pressure	400 bar

Inch

1.5 ft/sec
-22°F +212°F
6000 p.s.i.

Surface roughness

	μmRa	μmRt
Dynamic Sealing Face ØD_1	0.1 < > 0.4	4 max
Static Sealing Face Ød_1 Ød_2	1.6 max	10 max
Static Housing Faces Ød_3 L_1 L_2	3.2 max	16 max

	μinCLA	μinRMS
4 < > 16	5 < > 18	
63 max	70 max	
125 max	140 max	

Chamfers & Radii

	5.0	7.0	8.0	9.0	11.0	12.5
Groove Section $\leq S$ mm	2.5	4.0	5.0	5.0	6.5	6.5
Min Chamfer C mm	0.4	0.4	0.4	0.8	0.8	0.8
Max Fillet Rad r_1 mm	0.4	0.4	0.4	0.4	0.4	0.4
Max Fillet Rad r_2 mm	0.2	0.2	0.2	0.2	0.4	0.4

Tolerances

	ØD_1	Ød_1	Ød_2	Ød_3	L_1	L_2
mm	H10	h9	h9	h11	+0.2 -0	+0.1 -0

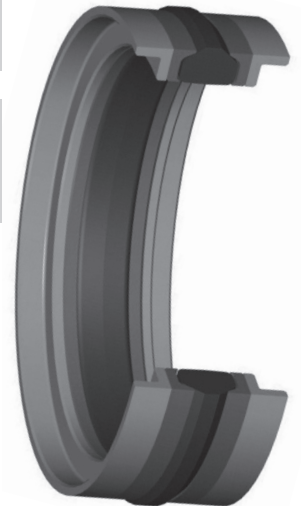

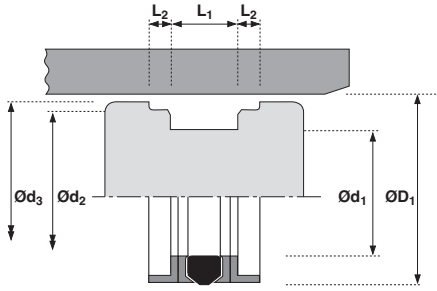

ØD ₁	TOL H10	Ød ₁	TOL h9	Ød ₂	TOL h9	Ød ₃	TOL h11	L ₁ +0.2 -0	L ₂ +0.1 -0	PART No.
32	+0.10 +0.00	22	+0.00 -0.05	28.0	+0.000 -0.052	31.0	+0.00 -0.16	15.5	2.60	6600100
40	+0.10 +0.00	26	+0.00 -0.05	36.0	+0.000 -0.062	39.0	+0.00 -0.16	15.5	2.60	6600200
50	+0.10 +0.00	34	+0.00 -0.06	46.0	+0.000 -0.062	49.0	+0.00 -0.16	20.5	3.10	6600300
55	+0.12 +0.00	39	+0.00 -0.06	51.0	+0.000 -0.074	54.0	+0.00 -0.19	20.5	3.10	6600400
60	+0.12 +0.00	44	+0.00 -0.06	56.0	+0.000 -0.074	59.0	+0.00 -0.19	20.5	3.10	6600500
63	+0.12 +0.00	47	+0.00 -0.06	59.0	+0.000 -0.074	62.0	+0.00 -0.19	20.5	3.10	6600600
65	+0.12 +0.00	49	+0.00 -0.06	61.0	+0.000 -0.074	64.0	+0.00 -0.19	20.5	3.10	1705210
70	+0.12 +0.00	54	+0.00 -0.07	66.0	+0.000 -0.074	69.0	+0.00 -0.19	20.5	3.10	6600700
80	+0.12 +0.00	62	+0.00 -0.07	76.0	+0.000 -0.074	79.0	+0.00 -0.19	22.5	3.60	1705110
90	+0.14 +0.00	72	+0.00 -0.07	86.0	+0.000 -0.087	89.0	+0.00 -0.22	22.5	3.60	6600800
100	+0.14 +0.00	82	+0.00 -0.09	96.0	+0.000 -0.087	99.0	+0.00 -0.22	22.5	3.60	6600900
110	+0.14 +0.00	92	+0.00 -0.09	106.0	+0.000 -0.087	109.0	+0.00 -0.22	22.5	3.60	6601000
125	+0.16 +0.00	103	+0.00 -0.09	121.0	+0.000 -0.100	124.0	+0.00 -0.25	26.5	5.10	6601100
140	+0.16 +0.00	118	+0.00 -0.09	136.0	+0.000 -0.100	139.0	+0.00 -0.25	26.5	5.10	6601200
160	+0.16 +0.00	138	+0.00 -0.10	156.0	+0.000 -0.100	159.0	+0.00 -0.25	26.5	5.10	6601300
250	+0.19 +0.00	225	+0.00 -0.12	246.0	+0.000 -0.115	249.0	+0.00 -0.29	31.5	6.60	6601400



Seal & Design
 Corporate Headquarters
 Ph: (716)-759-3344
 Info@SealAndDesign.com
 www.SealAndDesign.com