

Design

The Hallite 455 double acting piston seal provides the designer with a premium quality product to fit the industry standard NFPA (T3.19.18-1973) housing.

It comprises a bronze filled PTFE face ring, which is pre-loaded by a square section NBR ring. The cap ring is precision machined from a compression moulded billet. Compression moulding of the material offers consistently superior physical properties as compared to automatic moulded products. The machined face ring has chamfered corners for easy installation and a surface finish free from the "orange peel" effect associated with automatic moulded products.

As only the PTFE face ring is in contact with the sliding surface, friction is very low and stick slip movement is eliminated. The housing width allows the designer to use a narrow width piston, but it is recommended that an adequate bearing be mounted on either side of the seal as shown.

The Hallite 455 seal is not recommended for applications where it is necessary for the pressurized cylinder to maintain the load in a set position.

Materials

Standard materials are bronze / PTFE with a NBR square section energizer. Contact your Hallite technical representative for special applications and materials.

Features

- Precision machined bronze/ PTFE cap ring
- High strength compression moulded material
- Chamfered corners for easier installation
- Low friction, no 'stick up'
- Wide range of materials available

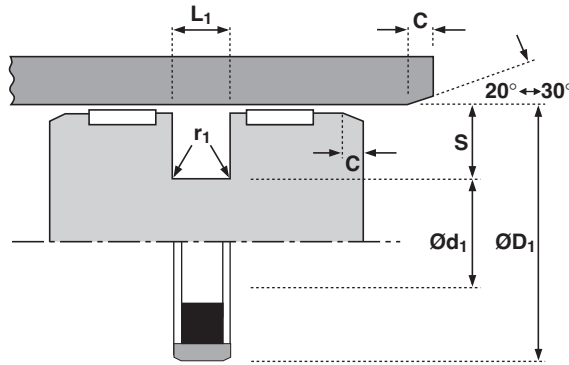

Technical details

Operating conditions

Maximum Speed	4.0 m/sec
Temperature Range	-30°C +100°C
Maximum Pressure	350 bar

Inch

12.0 ft/sec
-22°F +212°F
5,000 p.s.i.

Maximum extrusion gap

Pressure p.s.i.	1500	2400	3750	5250
Maximum Gap in	0.024	0.020	0.018	0.014

Figures show the maximum permissible gap all on one side using minimum clearance Ø and maximum bore Ø.

Surface roughness

Dynamic Sealing Face ØD ₁	µmRa	µmRt	µinCLA	µinRMS
Static Sealing Face Ød ₁	0.1 > 0.4	4 max	4 > 16	5 > 18
Static Housing Faces L ₁	1.6 max	10 max	63 max	70 max
	3.2 max	16 max	125 max	140 max

Chamfers & Radii

Groove Length L ₁	0.129	0.284	0.379
Min Chamfer C in	0.125	0.260	0.325
Max Fillet Rad r ₁ in	0.016	0.024	0.032

Tolerances

	ØD ₁	L ₁	
	H9	±0.002	
L ₁ in	0.129	0.284	0.379
Ød ₁	±0.001	±0.002	±0.003



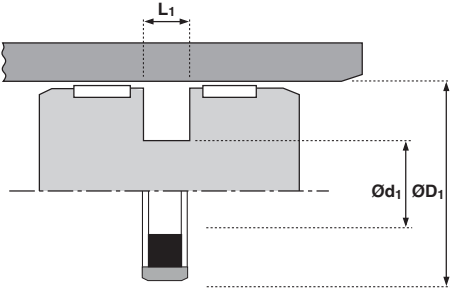

ØD ₁	TOL H9	Ød ₁	TOL	L ₁ + 0.002	PART No.
1.000	+0.002 +0.000	0.690	+0.001 -0.001	0.129	7280010
1.250	+0.002 +0.000	0.940	+0.001 -0.001	0.129	7280110
1.500	+0.002 +0.000	1.190	+0.001 -0.001	0.129	7280210
1.750	+0.002 +0.000	1.440	+0.001 -0.001	0.129	7280310
2.000	+0.003 +0.000	1.690	+0.001 -0.001	0.129	7280410
2.250	+0.003 +0.000	1.940	+0.001 -0.001	0.129	7280510
2.500	+0.003 +0.000	2.190	+0.001 -0.001	0.129	7280610
2.750	+0.003 +0.000	2.440	+0.001 -0.001	0.129	7280710
3.000	+0.003 +0.000	2.440	+0.002 -0.002	0.284	7280810
3.250	+0.003 +0.000	2.690	+0.002 -0.002	0.284	7280910
3.500	+0.003 +0.000	2.940	+0.002 -0.002	0.284	7281010
3.750	+0.003 +0.000	3.190	+0.002 -0.002	0.284	7281110
4.000	+0.003 +0.000	3.440	+0.002 -0.002	0.284	7281210
4.250	+0.003 +0.000	3.690	+0.002 -0.002	0.284	7281310
4.500	+0.003 +0.000	3.940	+0.002 -0.002	0.284	7281410
4.750	+0.004 +0.000	4.19	+0.002 -0.002	0.284	7281510

ØD ₁	TOL H9	Ød ₁	TOL	L ₁ + 0.002	PART No.
5.000	+0.004 +0.000	4.440	+0.002 -0.002	0.284	7281610
5.250	+0.004 +0.000	4.488	+0.002 -0.002	0.379	7281710
5.500	+0.004 +0.000	4.738	+0.003 -0.003	0.379	7281810
5.750	+0.004 +0.000	4.988	+0.003 -0.003	0.379	7281910
6.000	+0.004 +0.000	5.238	+0.003 -0.003	0.379	7282010
6.500	+0.004 +0.000	5.738	+0.003 -0.003	0.379	7282110
7.000	+0.004 +0.000	6.238	+0.003 -0.003	0.379	7282210
7.500	+0.005 +0.000	6.738	+0.003 -0.003	0.379	7282310
8.000	+0.005 +0.000	7.238	+0.003 -0.003	0.379	7282410
8.500	+0.005 +0.000	7.738	+0.003 -0.003	0.379	7282510
9.000	+0.005 +0.000	8.122	+0.003 -0.003	0.379	7282610
10.000	+0.005 +0.000	9.122	+0.003 -0.003	0.379	7282710
11.000	+0.005 +0.000	10.122	+0.003 -0.003	0.379	7282810
12.000	+0.005 +0.000	11.122	+0.003 -0.003	0.379	7282910
13.000	+0.006 +0.000	12.122	+0.003 -0.003	0.379	7283010
14.000	+0.006 +0.000	13.122	+0.003 -0.003	0.379	7283110



Seal & Design
Corporate Headquarters
Ph: (716)-759-3344
Info@SealAndDesign.com
www.SealAndDesign.com